

Hawk Evo VFA

The Hawk Evo VFA (Variable Forward Arm) is perfect for contractors and municipal environments, where the added benefits of a forward arm is required to improve visibility.

With a maximum reach of 6m, the Hawk Evo VFA can cope with every job it is tasked with. The impressive 1.8m maximum travel on the variable forward arm (VFA) gives 1.6m forward working.

Key Features

- 6.0m reach
- Over 1.8m traverse on variable forward arm
- Heavy duty linkage or axle bracket mounted
- 125 l/min independent system



Want to know more about the Hawk Evo VFA?

Scan the QR code to the left with a smart phone or tablet and compatible app to instantly view the page.

Alternatively visit: <http://www.bomford-turner.com/landscape/arm-mowers/hawk-evo-vfa/>



Transport bracket
Supplied as standard for fast travelling on the road.



Massive 1.6m forward reach
For optimum viewing position when working.



Clear visibility
Variable forward reach brings cutting head into drivers view.

Product Specification

● Standard ○ Optional — Not Available

Hawk Evo VFA	6.0m (19'8")
Tractor requirements	
Minimum horse power	80hp
Minimum weight	4600kg/10151lbs
Base unit mounting options	
Front mount	—
Mid-mount	—
Rear mount	●
Three point linkage (CAT II)	●
Axle bracket	○
Overall machine parameters	
Machine weight with head and oil	1860kg/4100lbs
Capacity of oil tank	200L/ 52.8USG
Weight of machine with oil but without head	1600kg/3527lbs
Controls	
Cable Control (CC)	●
Low pressure hydraulics (LPH)	—
Electronic proportional control (EPP)	○
Intelligent control system (ICS)	○
Cable rotor reverse	●
Electronic rotor reverse	○
Hydraulic System	
System capability	74hp
Pump flow rate	125L/ 33USG
Pump type (Gear / Piston / Helical)	Gear
Pump arrangement (Twin / Tandem Inline)	Twin
Independent hydraulics	●
Oil cooler	●

Hawk Evo VFA	6.0m (19'8")
Arm features and main frame	
Forward arm	1600mm / 5'3"
Telescopic arm	—
Telescopic arm stroke	—
Power slew	●
Power slew angle	94°
Gravity breakout protection	—
Hydraulic breakout protection	●
Arm float - manual operation	○
Arm float - electronic operation	○
Head float - manual operation	○
Head float - electronic operation	●
Left hand cutting	○
Right hand cutting	○
Left and right hand cutting	—
Arm attachments available	
Variable track bracket (VTB)	—
Sheartrim cutter bar	○
Pro-Saw	○
Ditch cleaner	○
Rotary head	○
Accessories	
Road lights	●
Debris blower	○
Warning arrow - Magnetic	○
Cab guard kit	●
Cutting heads (For Flail compatibility see page 95)	
1.2m Pro-Trim head with 115/150mm roller	○
1.5m Pro-Trim head with 115/150mm roller	○
1.2m Pro-Trim ISMP with 115mm roller	○
1.2m Pro-Cut head with 115/150mm roller	○
1.5m Pro-Cut head with 115/150mm roller	○
1.2m Pro-Cut ISMP with 150mm roller	○



Variable Forward Arm
The VFA allows total flexibility of position during arms operation.

Working Reach

Head used for calcs: 1.2m Pro-Trim

Side Reach Hawk Evo 6.0 VFA (19'8")	
A	6.0m / 19'8"
B	5.96m / 19'7"
C	4.18m / 13'9"
D	4.99m / 16'5"
E	6.16m / 20'3"
X	1.35m / 4'5"
Y	1.00m / 3'4"

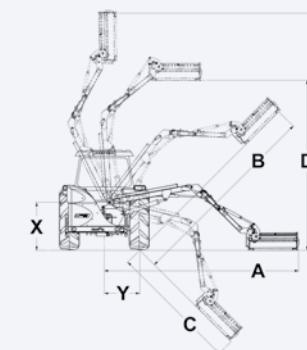

Forward Reach Hawk Evo 6.0 VFA (19'8")	
A	6.0m / 19'8"
F	5.39m / 17'8"
G	5.9m / 19'4"
H	1.6m / 5'3"
J	0.56m / 1'10"

